

X-PRO Series Data Sheet

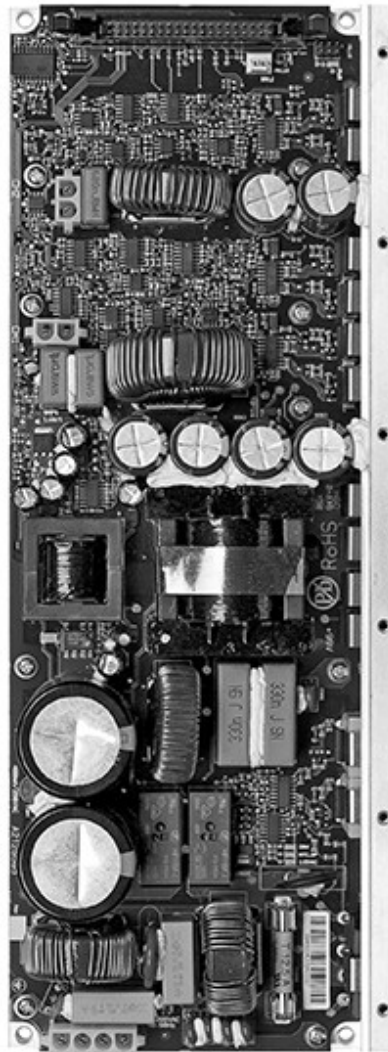

X-PRO1



X-PRO2



X-PRO3

Table of Contents

Product series outline.....	3
Absolute maximum ratings.....	3
Audio specifications.....	4
Input & Output loading.....	5
AC Mains and power loss specification	5
Audio measurements.....	6
Frequency response channel 1.....	6
Frequency response channel 2 & 3.....	6
Total Harmonic Distortion + Noise.....	7
Noise Spectrum	8
Intermodulation Distortion (CCIF, TIM).....	9
Cross Talk & Output impedance	10
Product connections and LED indicators.....	11
LED Functionality	11
LED timing during start-up & shut-down.....	11
Connectors.....	12
Open Collector Outputs.....	14
Fan Control.....	14
Power Up-/Down timing diagram.....	14
Single Ended (SE) & Bridge Tied Load (BTL) configuration	15
SE input configuration.....	15
BTL input configuration.....	15
Protection features.....	16
Over current protection	16
DC protection	16
Over-/under voltage protection	16
Mains fuse protection	16
Excessive power control (XPC).....	16
Temperature protection.....	16
Sleep Mode.....	16
High frequency protection	17
Readouts	17
Clip.....	17
Dis read/Protect.....	17
SMPS Limit.....	17
Output voltage	17
Output current.....	17
Temp Monitor.....	17
Mechanical Dimensions X-PRO1.....	18
Mechanical Dimensions X-PRO2.....	19
Mechanical Dimensions X-PRO3.....	20
Safety compliance	21
Electro Magnetic Compliance.....	21
ESD warning.....	21
Changes	21

Product series outline

The X-PRO Series is a true application dedicated series of complete “power packs” for the most demanding and powerful professional speaker applications, requiring high-end sonic quality as well as true professional reliability under any condition.

The X-PRO Series includes three different versions (X-PRO1, X-PRO2 and X-PRO3) each including a fully integrated universal mains power supply and up to 3 high performance Class D amplification stages.

Key features are outlined below:

- Plug'n'play integrated power package complete with all readout- and protection features for Professional applications, such as subwoofers, high power monitors and line arrays or small speaker systems. The complete integration secures optimal performance and reliability as well as shortened time to market.
- Fully protected high efficiency UREC™ switch mode power supply with auto selectable mains, enabling hassle free worldwide operation.
- Pascal proprietary UMAC™ Class D optimized amplifier power stages, with leading power performance specification and market acknowledged audio specifications.
- Complete interface, including extensive readouts and high auxiliary power for the most advanced DSP solutions.
- EMI and Safety compliant design.

Absolute maximum ratings

Symbol	Parameter	Value	Unit
V_{ACmax}	Maximum operational off-line voltage	265	V_{AC}
V_{ACmin}	Minimum operational off-line voltage	85	V_{AC}
f_{AC}	AC Mains frequency range	45 - 65	Hz
$I_{+15Vmax}$	Maximum +15V current draw ¹	150	mA
$I_{-15Vmax}$	Maximum -15V current draw ¹	-150	mA
I_{+7Vmax}	Maximum 7V current draw	1000	mA
$V_{in_p_max}$	Maximum peak input voltage, all channels	+/-15	V_p
$R_{load\ ch1}$	Minimum loudspeaker impedance ch1	4	Ω
$R_{load\ ch2, ch3}$	Minimum loudspeaker impedance ch2, ch3 (SE-mode)	4	Ω
$R_{load\ ch2, ch3}$	Minimum loudspeaker impedance ch2, ch3 (BTL-mode)	8	Ω
T_a	Maximum operating ambient temperature	60	$^{\circ}C$

Note 1: Ratings are given for an X-PRO3 module.

The +/- 15V supply on the X-PRO2 module can deliver 50mA more on each supply rail.

The +/- 15V supply on the X-PRO1 module can deliver 100mA more on each supply rail

Table 1: Absolute maximum ratings

Please note that measurements for Channel 2 and Channel 3 in the following sections are only applicable for X-PRO2 and X-PRO3 respectively.

Audio specifications

Symbol	Parameter	Conditions	Min	Typ	Max	Unit
V_{outmax_Ch1}	Peak output voltage Ch1	$R_L = 8\Omega$ $R_L = 4\Omega$		160 120		V
$V_{outmax_Ch2/Ch3}$	Peak output voltage Ch2/Ch3	$R_L = 8\Omega$ $R_L = 4\Omega$		80 80		V
I_{outmax_Ch1}	Peak output current			30		A
$I_{outmax_Ch2/Ch3}$	Peak output current			21		A
P_{o_tot}	Total module output power ¹ (power supply limited)	$230V_{AC}$ $120V_{AC}$		2200 2100		W
P_o	Output power Ch1 @ 1% THD+N 1kHz (AES17 filter)	$R_L = 8\Omega$ $230V_{AC}$ $120V_{AC}$		1550 1500		W
P_o	Output power Ch1 @ 1% THD+N 1kHz (AES17 filter)	$R_L = 4\Omega$ $230V_{AC}$ $120V_{AC}$		2000 2000		W
P_o	Output power Ch2/Ch3 @ 1% THD+N 1kHz (AES17 filter)	$R_L = 8\Omega$ $230V_{AC}$ $120V_{AC}$		400 400		W
P_o	Output power Ch2/Ch3 @ 1% THD+N 1kHz (AES17 filter)	$R_L = 4\Omega$ $230V_{AC}$ $120V_{AC}$		800 800		W
THD+N	THD+N (AES17 filter)	1kHz, 1W, $R_L = 8\Omega$		0.003		%
V_{noise_Ch1}	Output idle noise Ch1	Unweighted A-weighted		140 110		μV_{RMS}
$V_{noise_Ch2/Ch3}$	Output idle noise Ch2/Ch3	Unweighted A-weighted		75 55		μV_{RMS}
DR_{ch1}	Dynamic Range Ch1	Unweighted A-weighted		118 120		dB
$DR_{ch2/ch3}$	Dynamic Range Ch2/Ch3	Unweighted A-weighted		118 120		dB
A_{ch1}	Voltage gain Ch1	1kHz		32		dB
$A_{ch2/ch3}$	Voltage gain Ch2/Ch3	1kHz		26		dB
A_{var_Ch1}	Frequency response variance Ch1	20Hz - 20kHz All loads		+/-0.2		dB
$A_{var_Ch2/Ch3}$	Frequency response variance Ch2/Ch3	20Hz - 20kHz All loads		+/-0.1		dB
BW_{up_ch1}	Upper bandwidth Ch1 (-3dB)	$R_L = 8\Omega$ $R_L = 4\Omega$		70 60		kHz
BW_{low_ch1}	Lower bandwidth Ch1 (-3dB)	All loads		0.5		Hz
$BW_{up_ch2/ch3}$	Upper bandwidth Ch2/Ch3 (-3dB)	$R_L = 8\Omega$ $R_L = 4\Omega$		70 65		kHz
$BW_{l_ch2/ch3}$	Lower bandwidth Ch2/Ch3 (-3dB)	All loads		0.5		Hz
Z_{o_Ch1}	Absolute output impedance, Ch1	1kHz		11		m Ω
$Z_{o_Ch2/Ch3}$	Absolute output impedance, Ch2/Ch3	1kHz		6		m Ω
IMD_{CCIF_Ch1}	Intermodulation distortion (CCIF)	18kHz and 19kHz $P_o = 10W, 8\Omega$		0.001		%
TIM_{Ch1}	Transient Intermodulation distortion (TIM)	$P_o = 10W, 8\Omega$		0.003		%
$IMD_{CCIFCh2/Ch3}$	Intermodulation distortion (CCIF)	18kHz and 19kHz $P_o = 10W 8\Omega$		0.0008		%
$TIM_{Ch2/Ch3}$	Transient intermodulation distortion (TIM)	$P_o = 10W 8\Omega$		0.002		%

Note 1: All channels loaded with 8ohm. Maximum total power is limited by the power supply.

Table 2: Audio specifications

Input & Output loading

Symbol	Parameter	Conditions	Min	Typ	Max	Unit
Z _{INPUT}	Input impedance	Ch1, Ch2(SE), Ch3(SE)		1.88		kΩ
Z _L	Loudspeaker impedance range	Ch1, Ch2(SE), Ch3(SE)	4		inf	Ω
Z _L	Loudspeaker impedance range	Ch2, Ch3 (BTL)	8		inf	Ω

Table 3: Input & Output Loading

AC Mains and power loss specification

Symbol	Parameter	Conditions	Min	Typ	Max	Unit
P _{AC PN X-PRO1}	AC mains power input (Pink noise)	R _L = 8Ω		323		W _{RMS}
		R _L = 4Ω		411		
		R _L = 4Ω Nominal ¹ (RMS output = 1/8 of rated power)		228		
P _{AC PN X-PRO2}	AC mains power input (Pink noise, all channels)	R _L = 8Ω		396		W _{RMS}
		R _L = 4Ω		556		
		R _L = 4Ω Nominal ¹ (RMS output = 1/8 of rated power)		335		
P _{AC PN X-PRO3}	AC mains power input (Pink noise, all channels)	R _L = 8Ω		480		W _{RMS}
		R _L = 4Ω		685		
		R _L = 4Ω Nominal ¹ (RMS output = 1/8 of rated power)		459		
P _{120VAC NS X-PRO1}	AC mains power input (No signal applied)	Sleep Mode		3		W _{RMS}
		Disable (Mute)		10		
		Idle		18		
P _{120VAC NS X-PRO2}	AC mains power input (No signal applied)	Sleep Mode		3		W _{RMS}
		Disable (Mute)		12		
		Idle		25		
P _{120VAC NS X-PRO3}	AC mains power input (No signal applied)	Sleep Mode		3		W _{RMS}
		Disable (Mute)		16		
		Idle		32		
P _{230VAC NS X-PRO1}	AC mains power input (No signal applied)	Sleep Mode		6		W _{RMS}
		Disable (Mute)		12		
		Idle		19		
P _{230VAC NS X-PRO2}	AC mains power input (No signal applied)	Sleep Mode		6		W _{RMS}
		Disable (Mute)		14		
		Idle		27		
P _{230VAC NS X-PRO3}	AC mains power input (No signal applied)	Sleep Mode		6		W _{RMS}
		Disable (Mute)		18		
		Idle		34		
V _{AC Range 1}	Operational voltage range 120V _{AC}		85		138	V _{AC}
V _{AC Range 2}	Operational voltage range 230V _{AC}		170		265	V _{AC}
P _{Heat X-PRO1}	Heatsink power dissipation	R _L = 8Ω		123		W _{RMS}
		R _L = 4Ω		160		
		R _L = 4Ω Nominal ¹		85		
		(RMS output = 1/8 of rated power)				
P _{Heat X-PRO2}	Heatsink power dissipation (All channels)	R _L = 8Ω		147		W _{RMS}
		R _L = 4Ω		206		
		R _L = 4Ω Nominal ¹		117		
		(RMS output = 1/8 of rated power)				
P _{Heat X-PRO3}	Heatsink power dissipation (All channels)	R _L = 8Ω		180		W _{RMS}
		R _L = 4Ω		235		
		R _L = 4Ω Nominal ¹		166		
		(RMS output = 1/8 of rated power)				
T _{protection}	Temperature @ Thermal limiting			85		°C
T _{SD}	Temperature @ Thermal shutdown	Thermal hyst.= 10°C		95		°C

Note 1: Ch1 loaded with "4 Ohm SUB" which refers to a dual 18" driver bandpass subwoofer with a nominal impedance of 4 Ohm. Input signal filtered to 25Hz - 200Hz. Ch2/3 loaded with 4 Ohm resistive loads.

Table 4: AC Mains and power loss specification

Audio measurements

Frequency response channel 1

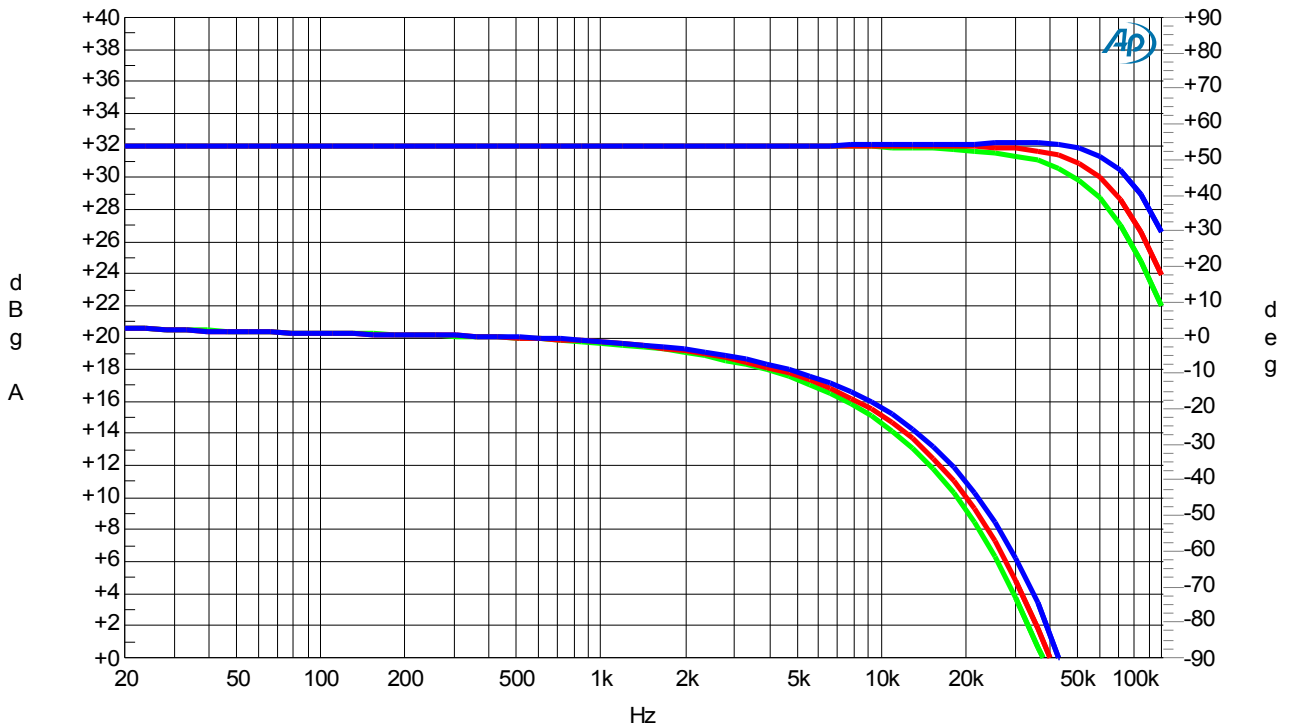

Frequency response, 4Ω (green), 8Ω (red) and open load (blue). Top - amplitude. Bottom - phase.

Frequency response channel 2 & 3

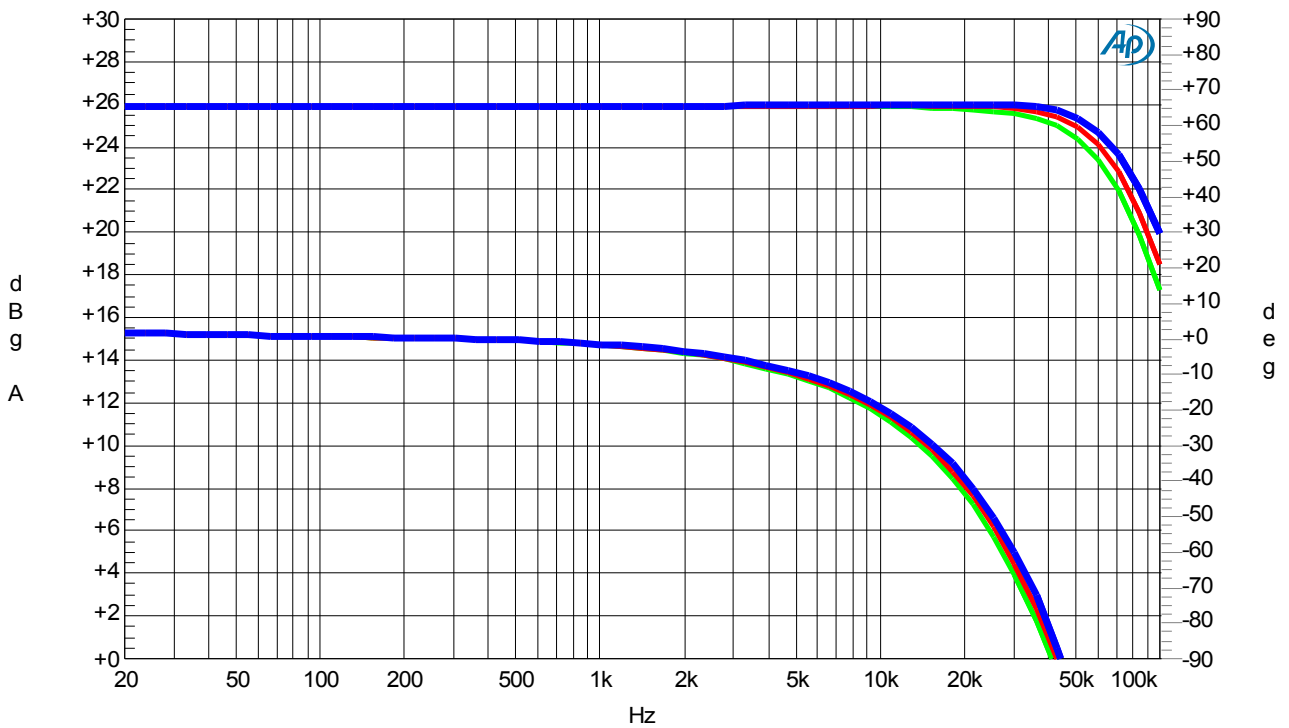

Frequency response, 4Ω (green), 8Ω (red) and open load (blue). Top - amplitude. Bottom - phase

Total Harmonic Distortion + Noise

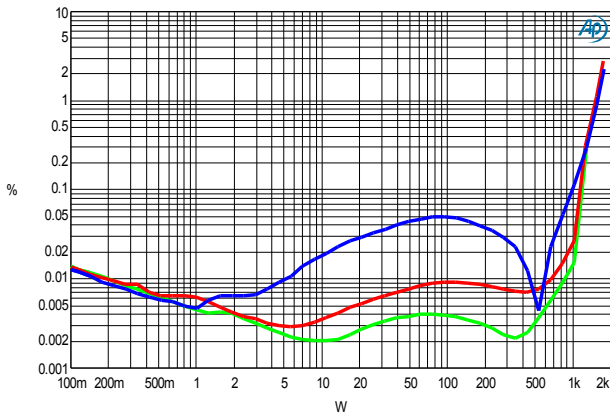

THD+N vs. Po, Channel 1, 100Hz (green), 1kHz (red), 6,67kHz (blue), 8Ω

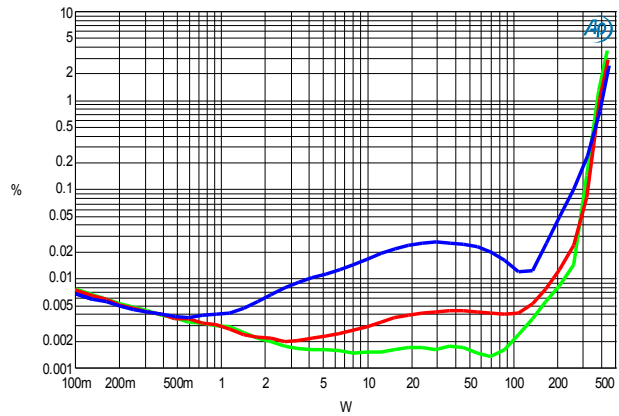

THD+N vs. Po, Channel 2 & 3, 100Hz (green), 1kHz (red), 6,67kHz (blue), 8Ω

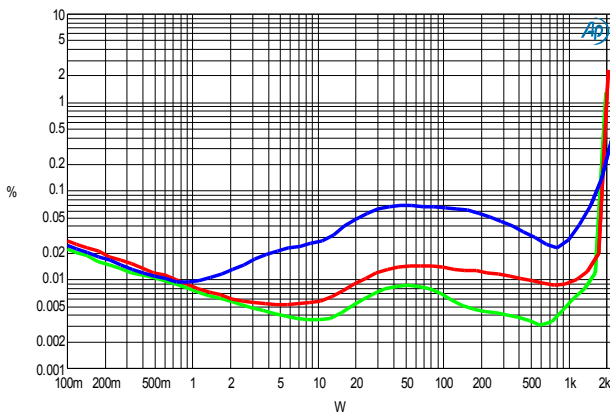

THD+N vs. Po, Channel 1, 100Hz (green), 1kHz (red), 6,67kHz (blue), 4Ω¹

Note 1: Above measurement is made by disabling the internal fuse protection - which can not normally be disabled. Normal power measurements should be done by using AP burst signals.

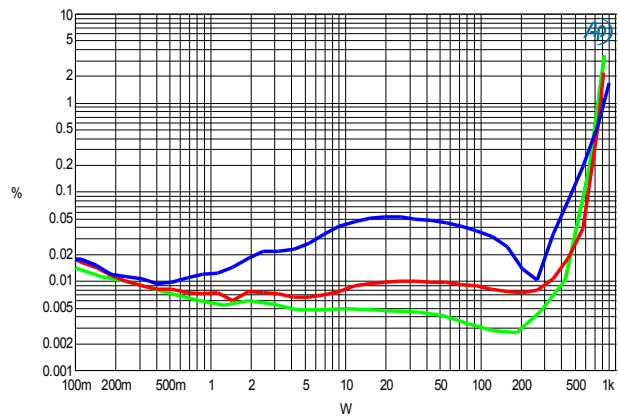

THD+N vs. Po, Channel 2 & 3, 100Hz (green), 1kHz (red), 6,67kHz (blue), 4Ω

Noise Spectrum

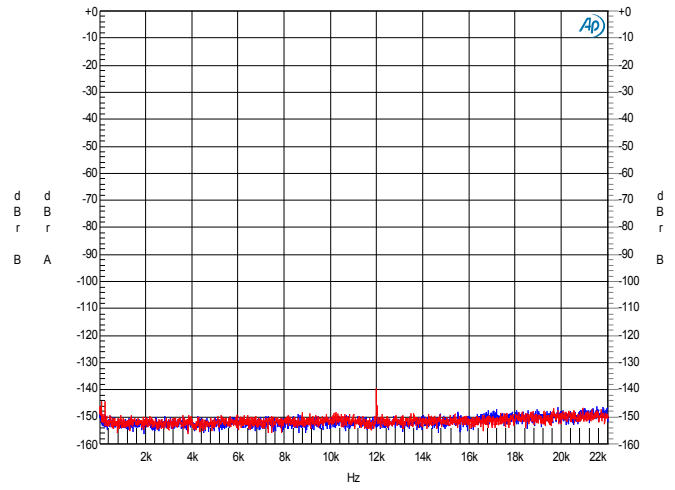
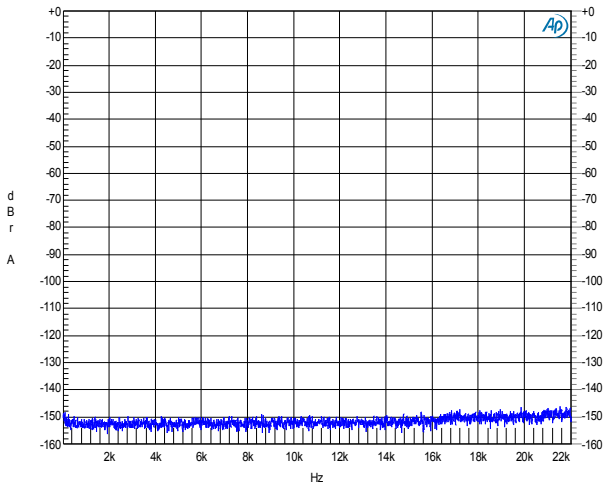

FFT, Channel 1, 4 Ohm, Idle

FFT, Channel 1 (Blue) & 2 (Red), 4 Ohm, Idle

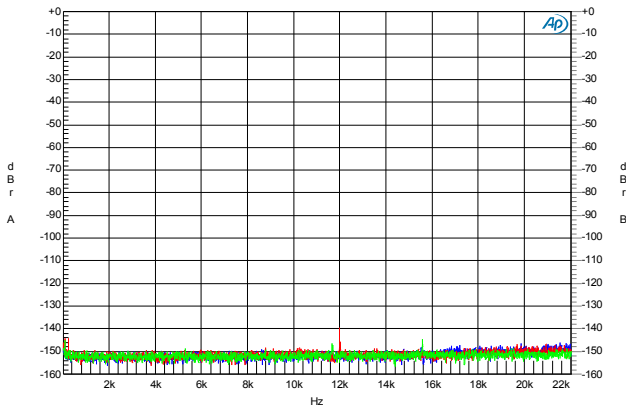

FFT, Channel 1(Blue), 2(Red) & 3(Green), 4 Ohm, Idle

Intermodulation Distortion (CCIF, TIM)

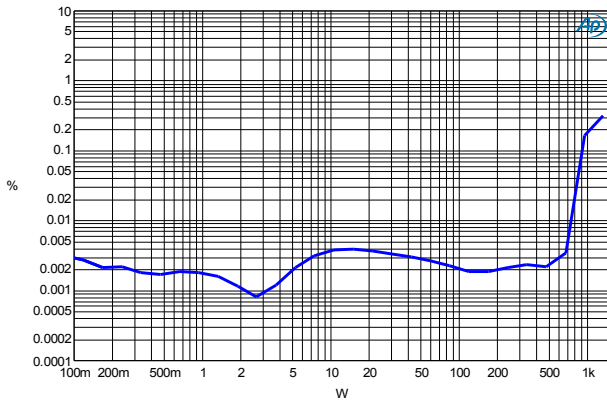

CCIF vs power $R_L=4$ ohm, channel 1, $f_1=18$ kHz, $f_2=19$ kHz

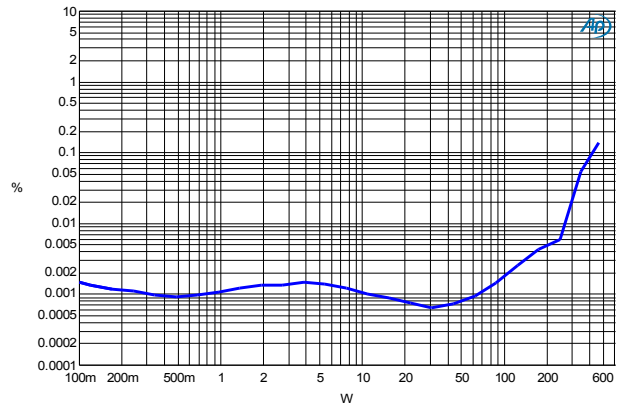

CCIF vs power $R_L=4$ ohm, channel 2/3, $f_1=18$ kHz, $f_2=19$ kHz

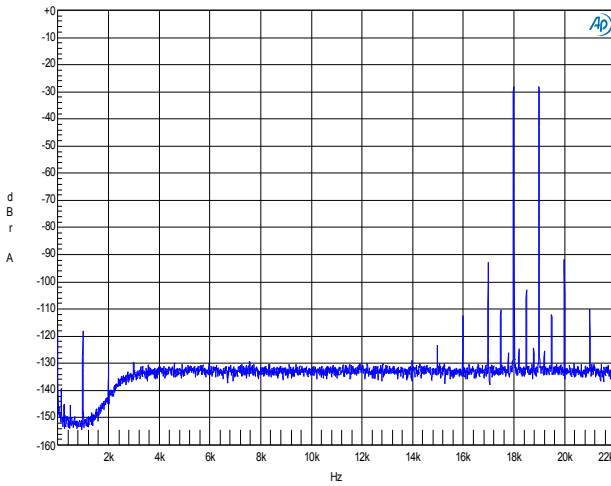

CCIF FFT, Channel 1, $f_1=18$ kHz, $f_2=19$ kHz $R_L=4$ Ohm, $P_0=10$ W.

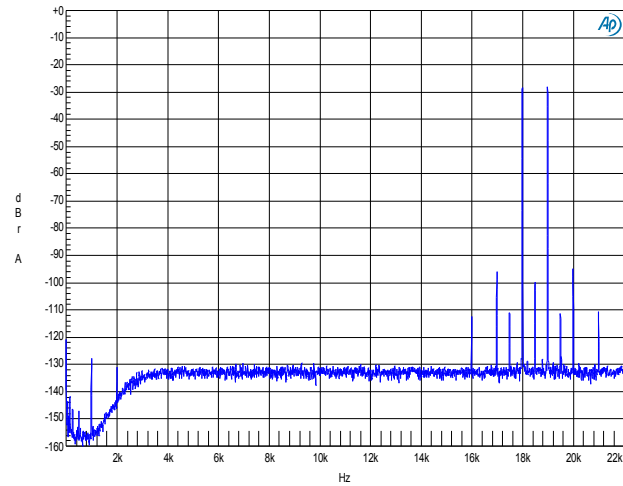

CCIF FFT, Channel 2/3, $f_1=18$ kHz, $f_2=19$ kHz $R_L=4$ Ohm, $P_0=10$ W.

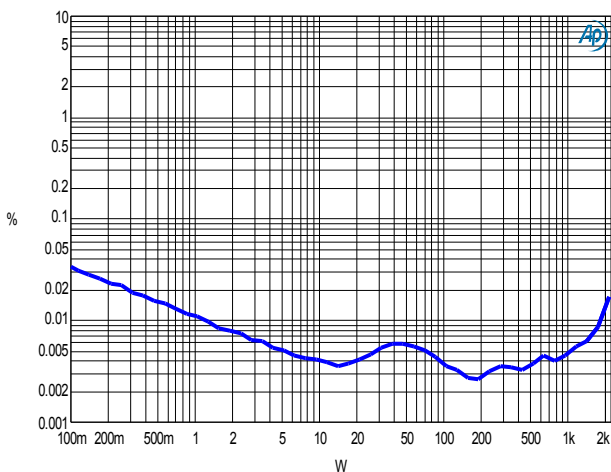

TIM vs. power, $R_L=4$ Ohm channel 1

Note 1: Above measurement is made by disabling the internal fuse protection - which can not normally be disabled. Normal power measurements should be done by using AP burst signals.

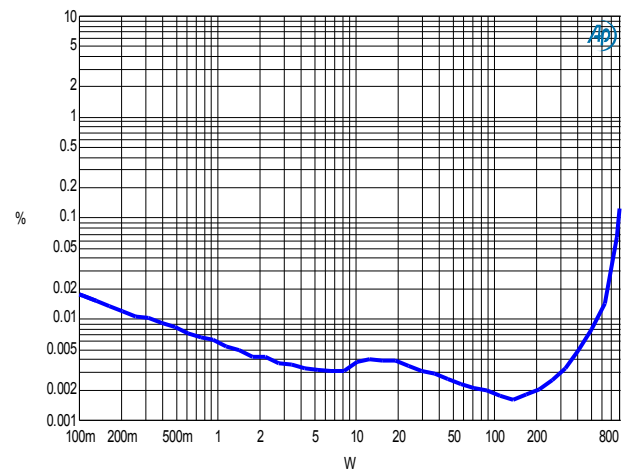

TIM vs. power, $R_L=4$ Ohm channel 2/3

Cross Talk & Output impedance

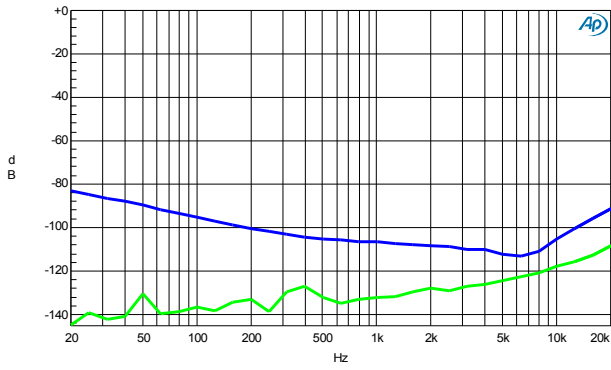

Cross talk, Channel 3, $P_{o,ch1}=100W$ (green),
Channel 3, $P_{o,ch2}=100W$ (blue)

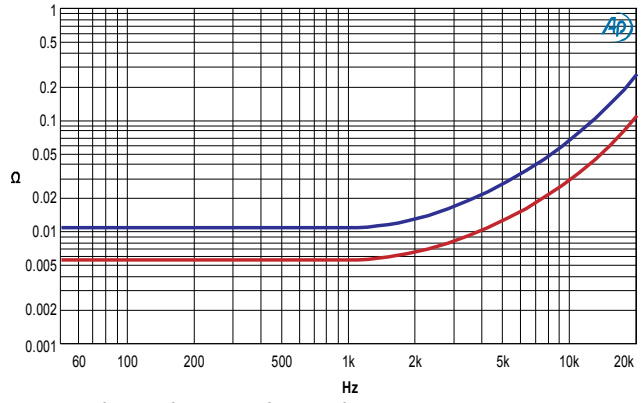

Output impedance, Channel 2/3, $I_{out}=1A_{RMS}$,
Channel 1, $I_{out}=1A_{RMS}$

Product connections and LED indicators

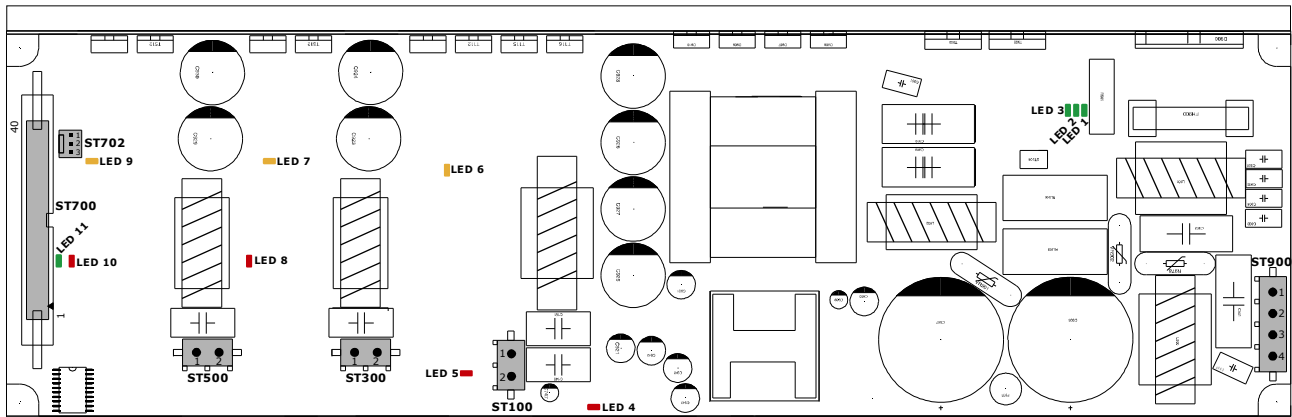

Figure 1: X-PRO3 Connectors and LEDs

LED Functionality

LED No.	Function	Normal Operation	LED Indication	LED Indication Result
LED 1	Relay 1 state	ON		Inrush limiter bypassed
LED 2	Relay 2 state	ON OFF		Mains AC voltage: 120V _{AC} Mains AC voltage: 230V _{AC}
LED 3	Amplifier drive voltage (Mains SMPS ON)	ON	On, Permanent Flashing	Amplifier drive voltage present, SMPS ON Disable (Mute) or Amplifier DC shutdown
LED 4	RMS Limiting	OFF	Flashing wo. input Flashing, with input On, Permanent	AC mains 120V/230V detection failed P _{AC Mains} = 1kW, periodical RMS limiting P _{AC Mains} > 1kW, permanent RMS limiting
LED 5	Clip Limiter _{CH1}	OFF	ON OFF	Channel 1, Clip limiting Channel 1, Not clipping
LED 6	Disable _{CH1}	OFF	ON OFF	Channel 1, Disable (Mute) or protection mode Channel 1, Enabled
LED 7	Disable _{CH2}	OFF	ON OFF	Channel 2, Disable (Mute) or protection mode Channel 2, Enabled
LED 8	Clip Limiter _{CH2}	OFF	ON OFF	Channel 2, Clip limiting Channel 2, Not clipping
LED 9	Disable _{CH3}	OFF	ON OFF	Channel 3, Disable (Mute) or protection mode Channel 3, Enabled
LED 10	Clip Limiter _{CH3}	OFF	ON OFF	Channel 3, Clip limiting Channel 3, Not clipping
LED 11	Auxiliary 5V	ON	ON OFF	Auxiliary 5V present Auxiliary 5V not present

Table 5: LED Functionality

LED timing during start-up & shut-down

During normal start-up and shut-down of the amplifier modules the LED's will show the following timing.

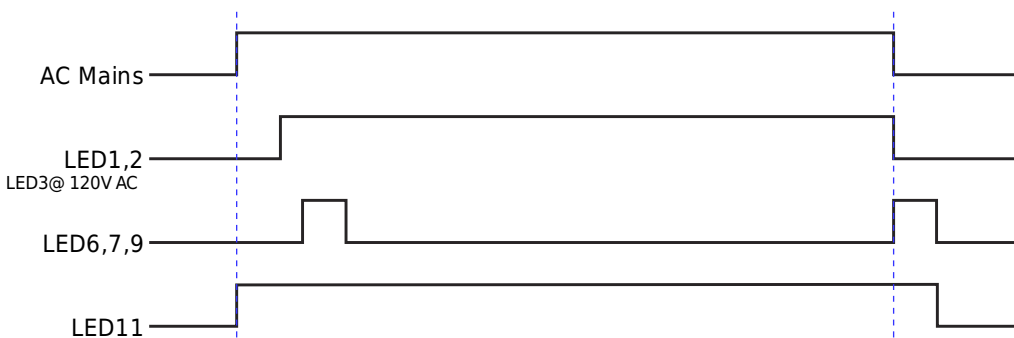

Figure 2: LED timing during start-up and shut-down

Connectors

AC Mains (ST900)		
Pin No.	Function	Note
Pin 1	AC Live	AC mains Live input
Pin 2	AC Neutral	AC mains Neutral input
Pin 3		No connection
Pin 4	Earth	Earthing of module, electrical contact to heat sink
PCB connector counterpart list:		
Cable connector housing part number: Molex (42021-4A)		
Cable connector pin part number: Molex (42024)		

Table 6: AC Mains (ST900) Connector

Speaker output (ST100)		
Pin No.	Function	Note
Pin 1	+Ch1 _{Out}	Amplifier channel 1, Out+
Pin 2	- Ch1 _{Out}	Amplifier channel 1, Out-
PCB connector counterpart list:		
Cable connector housing part number: Molex (42021-2A)		
Cable connector pin part number: Molex (42024)		

Table 7: Speaker output (ST100) Connector

Speaker output (ST300)		
Pin No.	Function	Note
Pin 1	+Ch2 _{Out}	Amplifier channel 2, Out+
Pin 2	- Ch2 _{Out} (GND)	Amplifier channel 2, GND
PCB connector counterpart list:		
Cable connector housing part number: Molex (42021-2A)		
Cable connector pin part number: Molex (42024)		

Table 8: Speaker output (ST300) Connector

Speaker output (ST500)		
Pin No.	Function	Note
Pin 1	+Ch3 _{Out}	Amplifier channel 3, Out+
Pin 2	- Ch3 _{Out} (GND)	Amplifier channel 3, GND
PCB connector counterpart list:		
Cable connector housing part number: Molex (42021-2A)		
Cable connector pin part number: Molex (42024)		

Table 9: Speaker output (ST500) Connector

Fan output (ST702)		
Pin No.	Function	Note
Pin 1	GND	GND
Pin 2	Fan output	Output for 5V fan
Pin 3	GND	GND
PCB connector counterpart list:		
Cable connector housing part number: Molex (10-11-2033)		
Cable connector crimp pin part number: Molex (9773789)		

Table 10: Fan output (ST702) Connector

Input & Output (ST700)			
Pin No.	Function	Type	Note
Pin 1	Signal Shield	AGND	Connect to analog GND at DSP-board
Pin 2	Signal return Channel 1	Input, SGND	Connect to ch1 signal source GND at DSP-board
Pin 3	Signal input channel 1	Input	4 V peak correspond to full output voltage, 32dB gain
Pin 4	Signal Shield	AGND	Connect to analog GND at DSP-board
Pin 5	Signal return Channel 2	Input, SGND	Connect to ch2 signal source GND at DSP-board
Pin 6	Signal input channel 2	Input	4 V peak correspond to full output voltage, 26dB gain
Pin 7	Signal Shield	AGND	Connect to GND at DSP-board
Pin 8	Signal return Channel 3	Input, SGND	Connect to ch3 signal source GND at DSP-board
Pin 9	Signal input channel 3	Input	4 V peak correspond to full output voltage, 26dB gain
Pin 10	Signal Shield	AGND	Connect to GND at DSP-board
Pin 11	V Out monitor channel 1	Output	+/- 10 V _p correspond to +/- 160 V on output
Pin 12	V Out monitor channel 2	Output	+/- 10 V _p correspond to +/- 80 V on output
Pin 13	V Out monitor channel 3	Output	+/- 10 V _p correspond to +/- 80 V on output
Pin 14	I Out monitor channel 1	Output	+/- 10 V _p correspond to +/- 30 A on output
Pin 15	I Out monitor channel 2	Output	+/- 10 V _p correspond to +/- 20 A on output
Pin 16	I Out monitor channel 3	Output	+/- 10 V _p correspond to +/- 20 A on output
Pin 17	Temp monitor	Output	0-10 V correspond to 0 - 100 Degrees Celsius
Pin 18	GND (ref +/-15 V)	GND	
Pin 19	GND (ref +/-15 V)	GND	
Pin 20	Clip channel 1	Output, Active low	Open collector ¹
Pin 21	Clip channel 2	Output, Active low	Open collector ¹
Pin 22	Clip channel 3	Output, Active low	Open collector ¹
Pin 23	GND (ref +/-15 V)	GND	
Pin 24	Dis read/Protect	Output, Active low	Indicates amp channels switched off. Open collector ¹
Pin 25	GND (ref +/-15 V)	GND	
Pin 26	Disable (Mute)	Input, Active Low	Switches all amp channels off.
Pin 27	Not used (Do not connect)	Floating	Floating
Pin 28	SMPS Limit	Output, Active low	Indication before SMPS limiting Open collector ¹
Pin 29	Temp reduction off	Input, Active Low	Disables soft volume reduction at high temp.
Pin 30	Sleep mode	Input, Active Low	Shuts down all power circuitry - except +7 V
Pin 31	+7 V	Output	Maximum current 1.0 A (available also in sleep mode)
Pin 32	+7 V	Output	Maximum current 1.0 A (available also in sleep mode)
Pin 33	GND (ref +/-15 V)	GND	
Pin 34	GND (ref +/-15 V)	GND	
Pin 35	+15 V	Output	Maximum current 150 mA total on +15V
Pin 36	+15 V	Output	Maximum current 150 mA total on +15V
Pin 37	GND (ref +/-15 V)	GND	
Pin 38	GND (ref +/-15 V)	GND	
Pin 39	-15 V	Output	Maximum current 150 mA total on -15V
Pin 40	-15 V	Output	Maximum current 150 mA total on -15V
PCB connector counterpart list:			
Cable connector housing part number: Greenconn (GPHA220-2002B02A)			

Note 1: All open collector outputs have a 470Ω resistor in series with the open collector.

Table 11: Input & Output (ST700) Connector

Open Collector Outputs

All collector outputs are implemented as shown on the picture below. The 470Ω resistor is inserted to protect the open collector transistor and the 47pF capacitor has been implemented as EMI filtering.

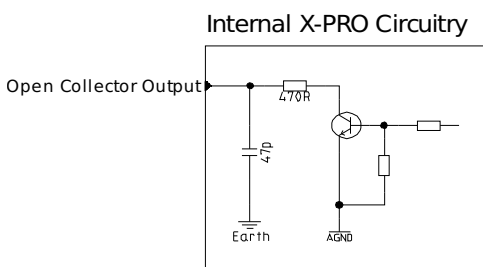

Figure 3.1: Open Collector Output

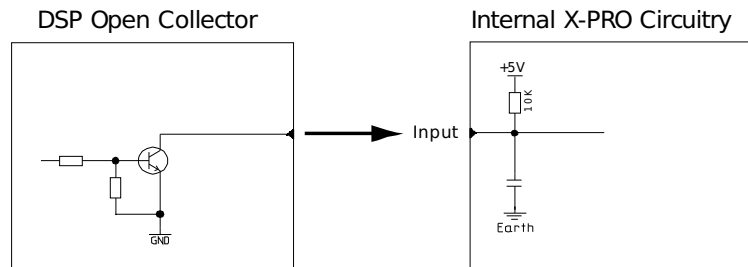

Figure 3.2 Input for open collector control

Fan Control

The fan control thermal limits can be seen from the table below. The fan control signal can be used for a 5V fan or as a control signal for a 230V_{AC} fan.

Fan threshold		
Parameter	T _{ON} (°C)	T _{Off} (°C)
T _{Powerstage}	60	40

Power Up-/Down timing diagram

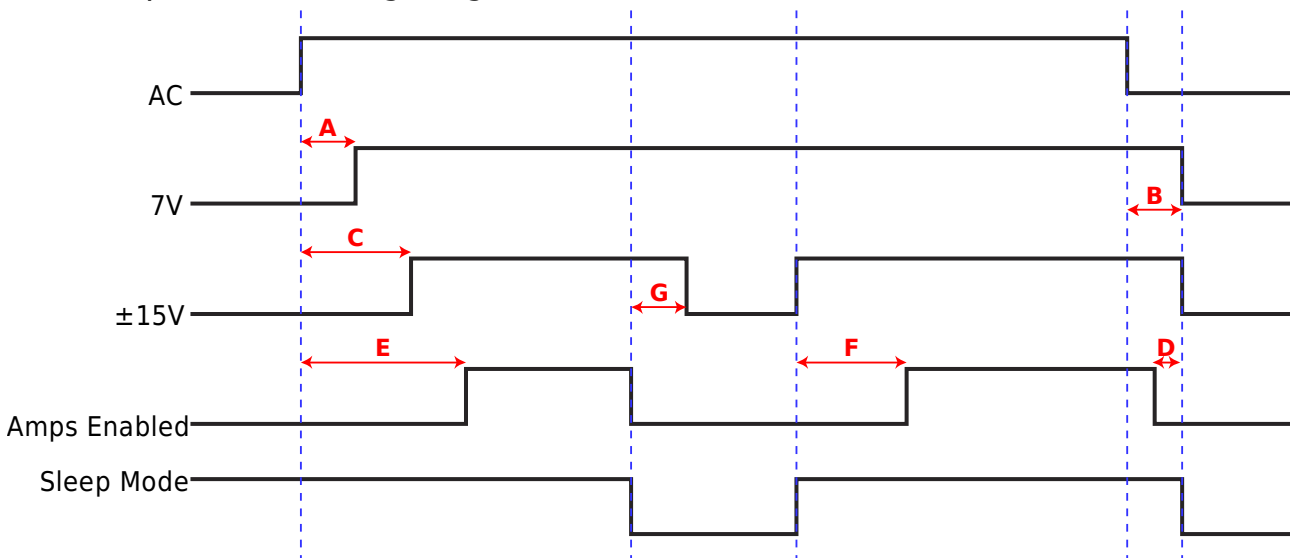

Figure 4: Power Up-/Down timing diagram

Parameter	Time (ms)	Condition
A	140ms	+/-15V and +7V, loaded with DEMO I/O board
B	3600ms	+/-15V and +7V, loaded with DEMO I/O board
C	2400ms	+/-15V and +7V, loaded with DEMO I/O board
D	1600ms	+/-15V and +7V, loaded with DEMO I/O board
E	4150ms	+/-15V and +7V, loaded with DEMO I/O board
F	4000ms	+/-15V and +7V, loaded with DEMO I/O board
G	270ms	+/-15V and +7V, loaded with DEMO I/O board

Table 12: Power Up-/Down timing specifications

Single Ended (SE) & Bridge Tied Load (BTL) configuration

Channel 2 and channel 3 of the X-PRO module can be operated in either SE or BTL mode¹.

SE input configuration

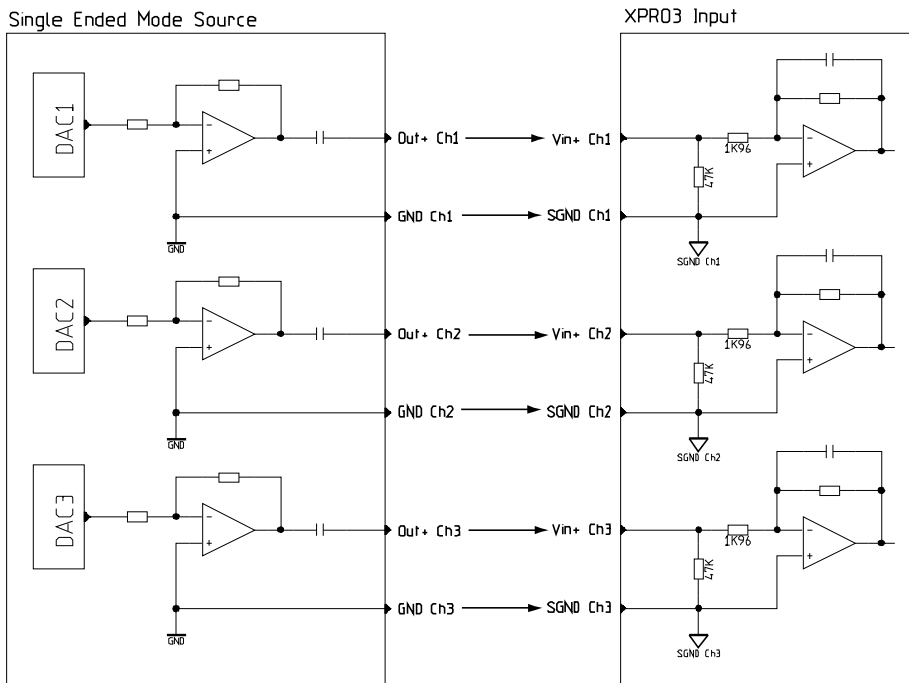

Figure 6: SE input configuration

BTL input configuration

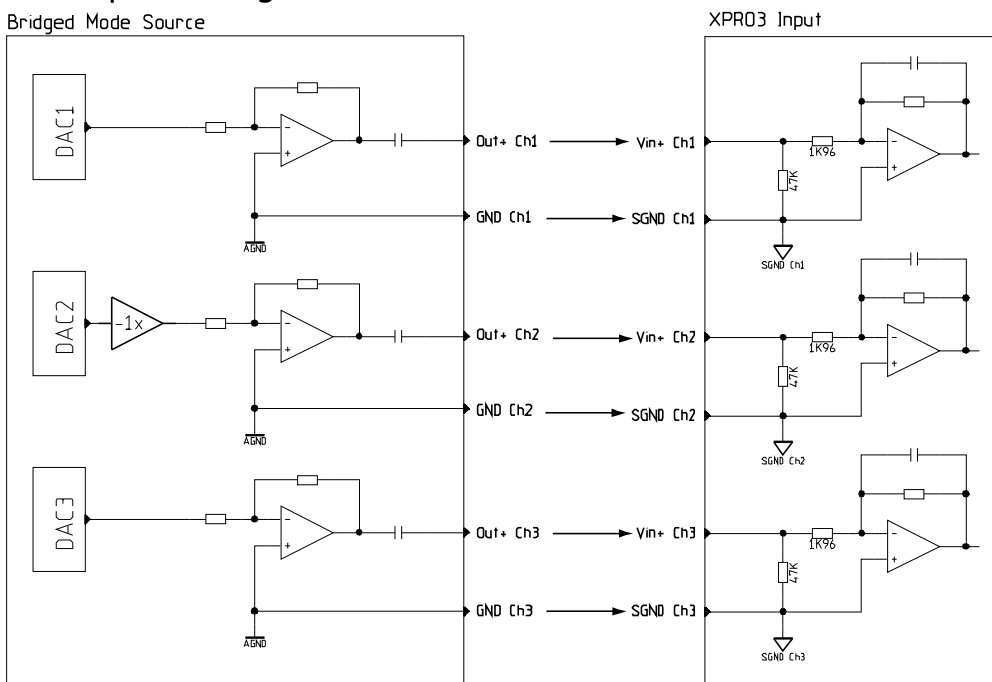

Figure 7: BTL input configuration

Note 1: For amplifier output loading in SE or BTL mode, please refer to Input & Output Loading section.

Protection features

Over current protection

All amplifier channels are over current protected on outputs.

Current clipping is engaged when the amplifier channels exceeds its specified peak current output¹. This can be seen as the output voltage of the amplifier being clipped.

If the current output of an amplifier channel exceeds its specified peak current output e.g in case of a short circuit of the output. In this case the amplifier will be disabled (Muted) for 1000ms and automatically restart.

Note 1: Please see audio specification section.

DC protection

A built-in DC protection circuit will attenuate any DC signals on the amplifier outputs, either produced by an input signal containing a DC signal or by malfunction of the amplifier.

In case of a signal input containing a DC or due to an amplifier malfunction, where the DC-protection circuit can not sufficiently attenuate an amplifier DC output signal, the amplifier will disable (Mute) and restart 3 times before latching, after which power must be removed in order to power up the product.

Over-/under voltage protection

Powersupply over- and undervoltage protection is implemented, which means that the powersupply will enter a protection mode when the operational off-line voltage exceeds or drops below the specified upper and lower operational off-line AC voltages. Exceeding 265V_{AC} for a longer period of time might damage the power supply permanently.

Mains fuse protection

Protection of the mains fuse in the product is implemented such that the RMS current flowing from the AC mains connection, will never exceed the fuse breaking current.

The Mains fuse protection also removes the risk of compromising safety in situations of overload.

The X-PRO series module fuse should never be replaced. In the case where a fuse is blown the product should be returned to Pascal, according to Pascal RMA procedures.

Excessive power control (XPC)

The internal amplifier powerstage overload protection ensures fast attenuation of signals in situations of amplifier overload. On real speaker applications power outputs are increased compared to resistive loads.

Temperature protection

Temperature protection of powerstages, transformers and heatsinks can be used in two different configurations:

1. Thermal limiter "ON": Limiting is engaged after the powerstage, transformer or heatsink temperature has reached it's specified thermal limiting temperatures.
After limiting is engaged, the amplifier will find it's thermal equilibrium.
2. Thermal limiter "OFF": The amplifier disables (Mutes) for a period of time and automatically restarts , after the powerstage, transformer or heatsink temperature have reached the specified thermal start-up temperature.

Sleep Mode

This function is designed as a special feature for installation purposes.

When the amplifier is put into Sleep Mode, major circuitry parts are powered down, which leads to the low AC mains power input specification of only a few watt.

The +7V supply rail is still active, which enables a possible network/DSP to remotely power up the amplifier again.

High frequency protection

A high frequency protection is implemented in order to protect filter components from overload.

The high frequency protection algorithm has been implemented to protect the amplifier from excessive HF signals on the the amplifier outputs.

The amplifiers have a full power bandwidth of 20 kHz, which will be allowed for unlimited time, 30kHz full power is allowed for 2 seconds before protection becomes active.

Readouts

Clip

When the amplifier output peak voltage or current exceeds the specified values, the amplifier channel will start clipping the Voltage/Current. Clipping indication has been implemented for each amplifier channel.

Clip indication for channel 1, 2 and 3 can be monitored from ST700, Pin 20, 21 and 22.

Dis read/Protect

The Dis read/protect indication is based on an open collector, indicating if any of the amplifier channels or the power supply is in disable (Mute) or in protect mode. This indicates either an external shutdown or an on-board protection condition. Dis Read/Protect can be monitored from ST700 pin 24.

SMPS Limit

In order to protect the power supply from overload, a power supply limiter is set.

The SMPS limit indication is based on an open collector and can be monitored from ST700 pin 28. The timing of the SMPS limit engagement can be seen below:

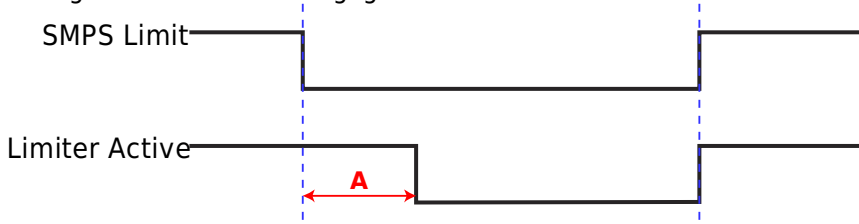

Figure 5: SMPS Limit

A = 1000 ms

Output voltage

Output voltage is measured on channel 1, 2 and 3 and supplied as a bi-directional sinusoidal voltage output. Output voltage for channel 1, 2 and can be measured on ST700 pin 11, 12 and 13.

Output current

Output current is measured on channel 1, 2 and 3 and supplied as a bi-directional sinusoidal voltage output. Output current for channel 1, 2 and can be monitored on ST700 pin 14, 15 and 16.

Temp Monitor

Temperature monitoring is made at several points in the amplifier and power supply. The maximum temperature of any measurement point is provided as the Temp Monitor, which can be monitored on ST700 pin 17.

Mechanical Dimensions X-PRO1

All dimensions in mm

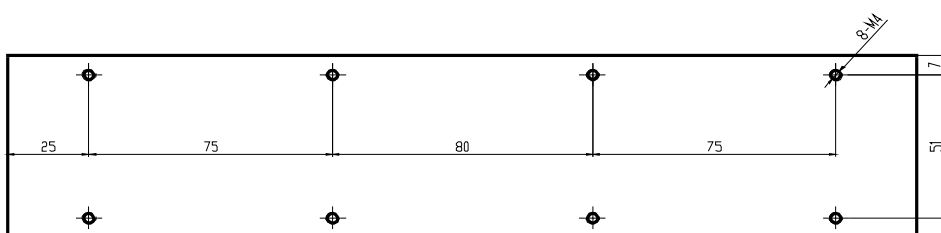
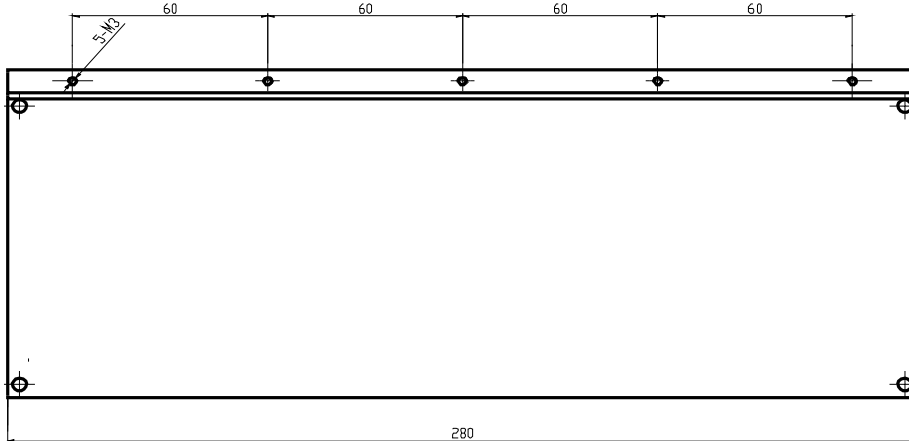
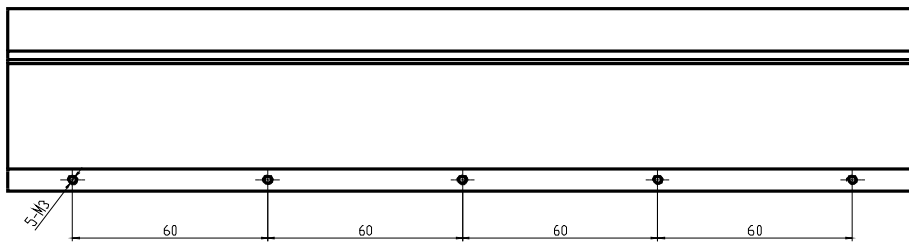
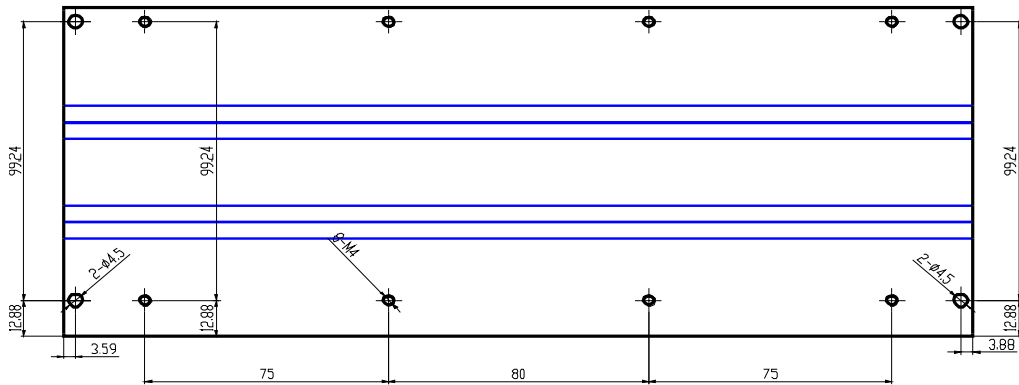
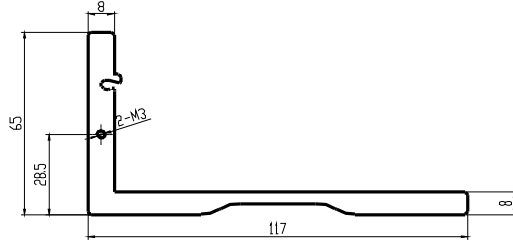
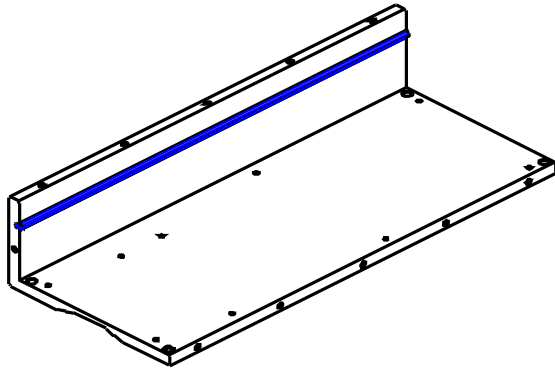

Mechanical Dimensions X-PRO2

All dimensions in mm

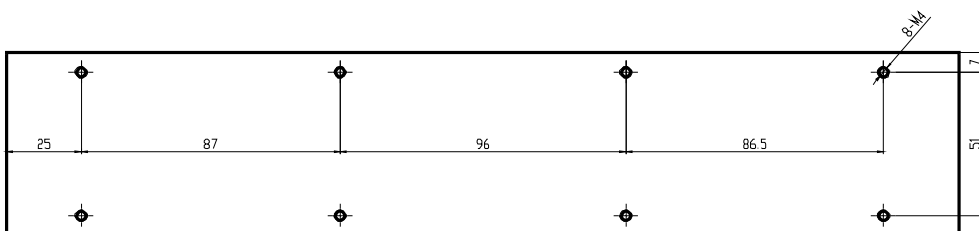
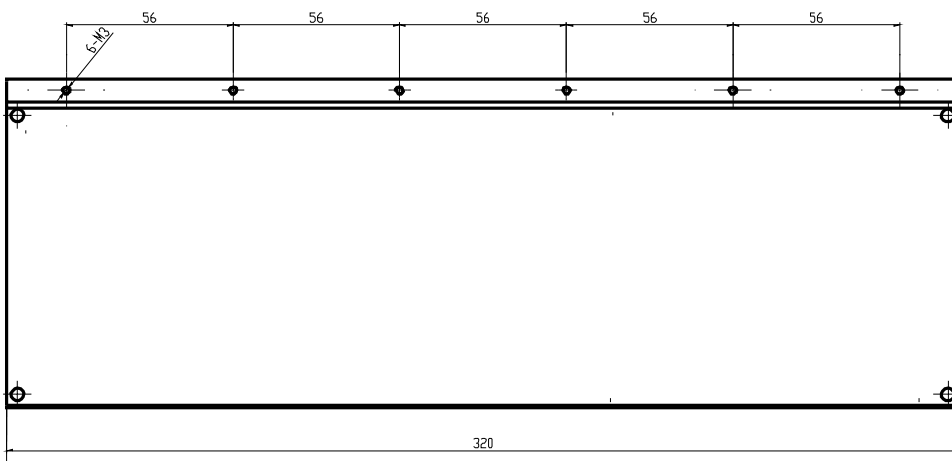
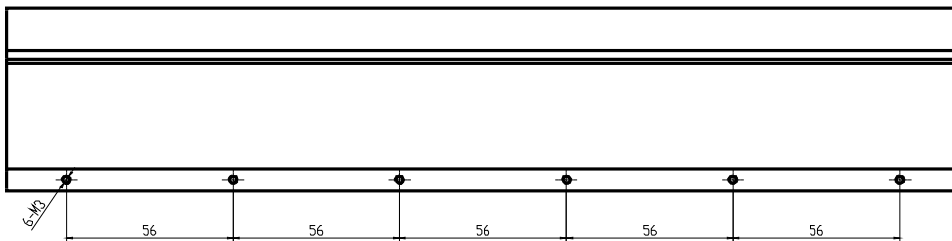
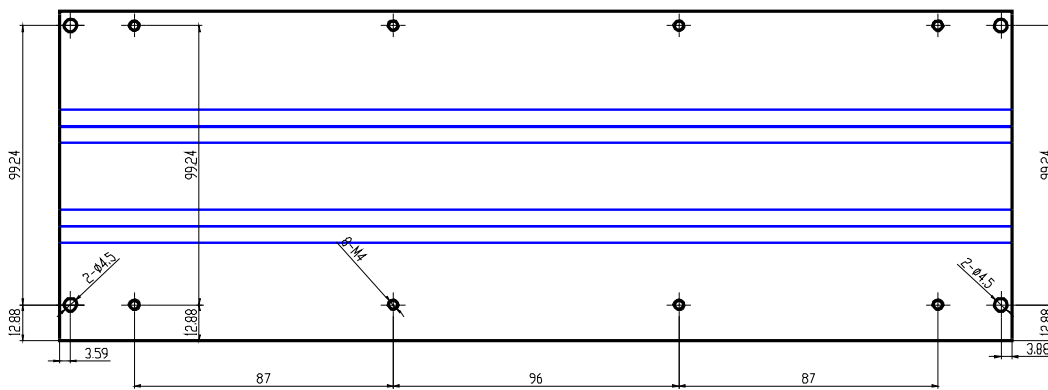
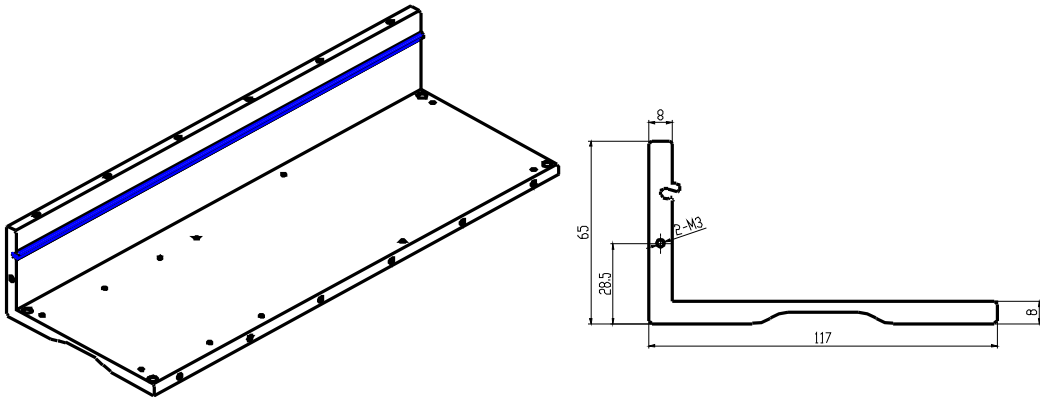

Safety compliance

X-PRO series modules are all safety tested, according to the following standards:

IEC60065: 2001 (7th Edition) + A1: 2005
EN60065: 2002 + A1:2006
UL60065: 2003, CSA C22.2 60065-03 + Am 1 (2006)

Test procedure: CB
X-PRO series CB certificate no. available on request.

Product safety category: Class 1 (Earthed equipment)

Electro Magnetic Compliance

Pascal amplifier modules are EMI compliance tested according to the following standards.

EN55103-1 Emission

EN55103-2 Immunity

EMI verification measurements of the final product, should be carried out in order to secure compliance of the final product.

ESD warning

In order to retain the right to Pascal warranty on products, precautions on ESD must be taken when handling Pascal products. Handling of Pascal products should comply to the following standards.

IEC 61340-5-2: Protection of electronic devices from electrostatic phenomena. User Guide.
IEC 61340-5-1: Protection of electronic devices from electrostatic phenomena. General Requirements.
ANSI/ESD-S20.20-1999: Protection of Electrical and Electronic Parts, Assemblies and Equipment.

Changes

Pascal Products are continuously undergoing smaller changes to improve the performance or to comply with manufacturing and quality requirements. Therefore specifications in this datasheet, might be subject to change.

For further information

www.pascal-audio.com

Or contact us at:
Info@pascal-audio.com
Phone +45 3699 1944

Pascal A/S
Literbuen 10B
2740 Skovlunde
Denmark